



RAM

Audio®

DSP_PowerPack™ • ASYM Series

AS 1K5

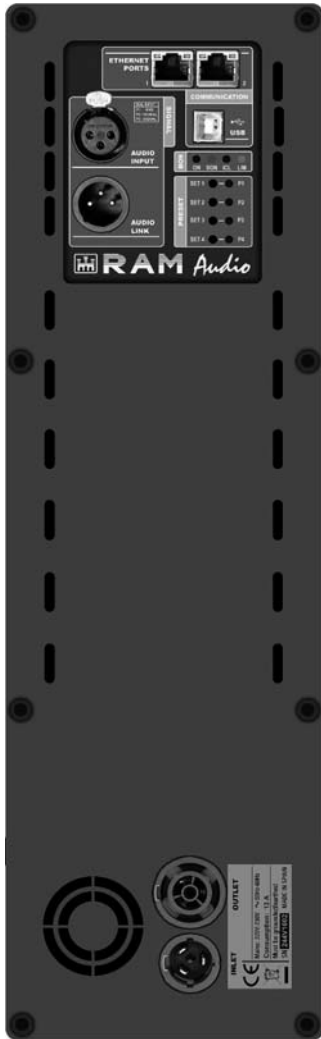

AS 2K3



OPERATION MANUAL BEDIENUNGSANLEITUNG MANUAL DE USUARIO



Module Assembly

Installation Requirements

For the installation of the ASYM module you need an internal chamber inside the acoustic enclosure, separate from the chamber where the speaker is mounted. If preferred, the ASYM module can be supplied with a rear metal case for this purpose, avoiding having to make this space airtight.

The module is fixed to the enclosure with 8 M4 or M5 screws, sealing foam should be placed in the joint between the module and the box to avoid vibrations (it is not advisable to put foam in the joint between the module and the optional rear metal case).

In the drawings below you can see: (1) the external dimensions of the module (front/profile), (2) the optional rear metal case, and also (3) the recommended machining of the acoustic enclosure.

Modul Zusammenbau

Installationsvoraussetzungen

Für die Installation des ASYM Moduls wird ein eigenes Volumen im Lautsprechergehäuse benötigt, welches separat von dem des Lautsprechers ist. Wenn gewünscht kann das ASYM Modul mit einer metallenen Schale versehen werden, um diesen Bereich nicht extra luftdicht machen zu müssen. Das Modul wird mit 8 M4 oder M5 Schrauben am Gehäuse befestigt, in den Spalt zwischen Modul und Gehäuse sollte Dichtschaum gegeben werden, um Vibrationen zu vermeiden (Es ist nicht ratsam zwischen dem Modul und dem optionalen metallenen rückwärtigen Gehäuse ebenfalls Dichtschaum zu geben).

In den Zeichnungen weiter unten kann man folgendes sehen: (1) Die äußeren Abmessungen des Moduls (von Vorne, von der Seite), (2) das optionale rückwärtige Gehäuse und (3) auch die benötigte Aussparung des Lautsprechergehäuses.

Montaje del Módulo

Requisitos de Instalación

Para la instalación del módulo ASYM es necesario tener una cámara interna en el recinto acústico, separada de la cámara donde está montado el altavoz. Opcionalmente, el módulo ASYM puede ser suministrado con un cajón metálico trasero para este propósito, y así evitar tener que hacer este alojamiento hermético en el recinto.

La sujeción del módulo al recinto se realiza mediante 8 tornillos M4 o M5, y debe colocarse una junta de espuma entre el módulo y la caja para evitar vibraciones (no es recomendable poner esta junta entre el módulo y el cajón metálico opcional).

En los planos bajo estas líneas se muestran: (1) las dimensiones externas del módulo (frontal/perfil), (2) las del cajón opcional, así como (3) el mecanizado recomendado a realizar en el recinto acústico.

(1) Profile-Front Dimensions

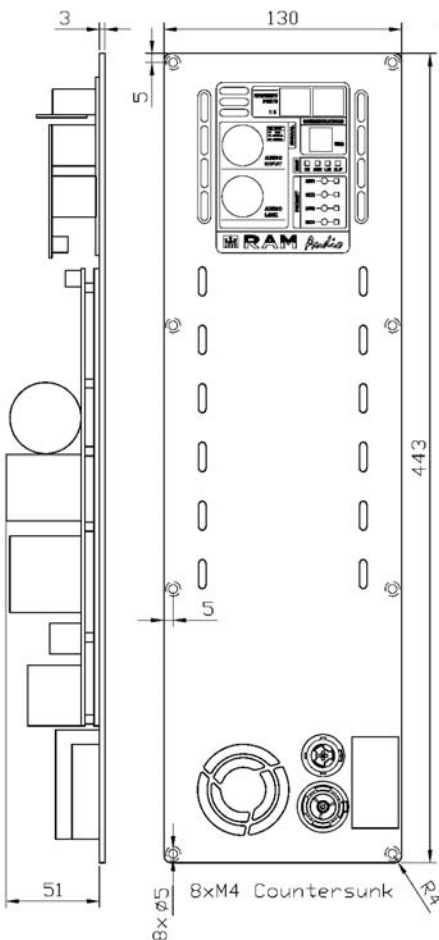

(2) Optional Aluminium Case

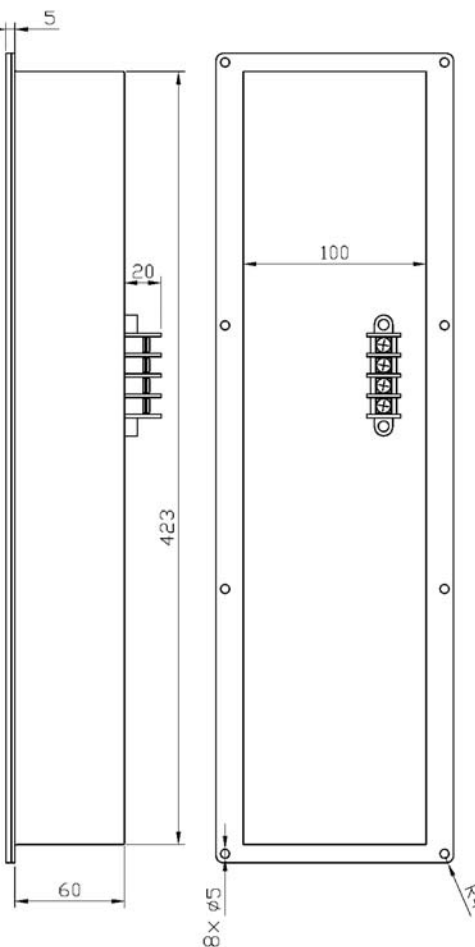

(3) Cabinet Mechanization

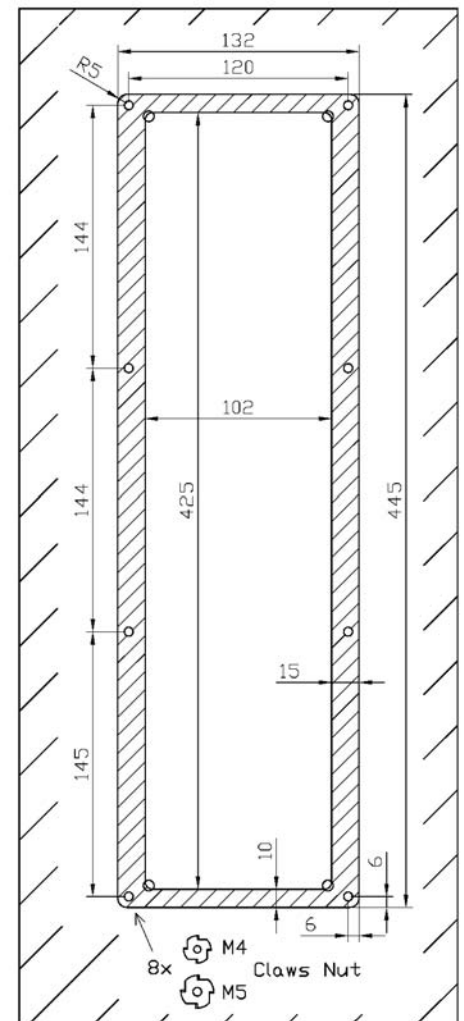

Connection and Description

Verbindung und Beschreibung

Conexión y Descripción

Speakers Connection

The connection of the speakers to the module is done using two JST VHR-2N connectors provided. A cable should be crimped to the terminals (1.25mm² section maximum) and placed on the connector box, so that the metallic tab fits into place.

The connection is as follows:

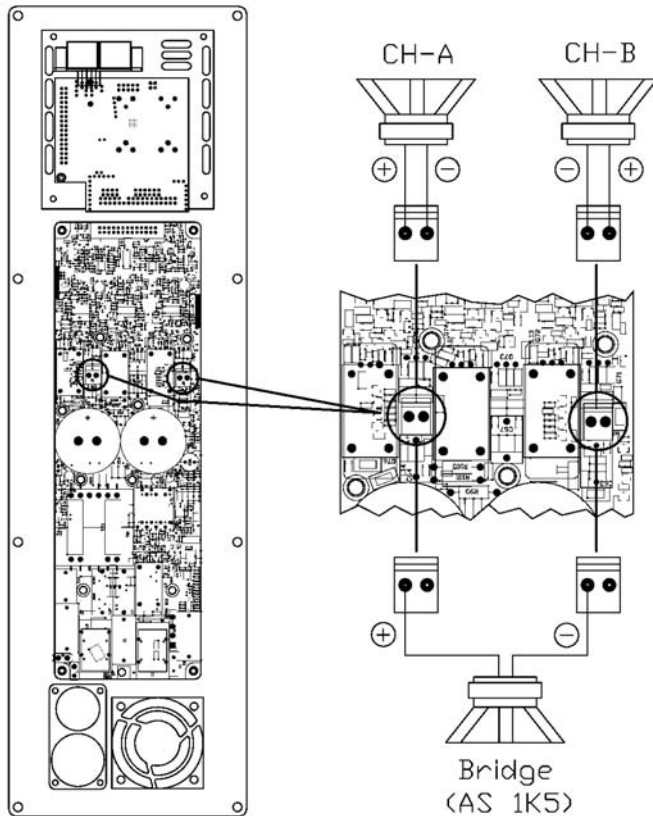

Lautsprecher Anschluss

Der Anschluss der Lautsprecher am Modul erfolgt durch zwei JST VHR-2N Stecker. Ein Kabel wird auf die Anschlussstifte gecrimpt (maximal 1,25mm²) und ins Steckergehäuse gesteckt, so dass der metallene Stift einrastet.

Der Anschluss erfolgt wie folgt:

Conexión de Altavoces

La conexión de los altavoces al módulo se realiza a través de 2 conectores JST VHR-2N suministrados. Debe de crimparse un cable a los terminales (sección máxima de 1.25mm²) e introducir los mismos sobre la caja del conector, de forma que la pestaña metálica se aloje en su hueco. El conexionado es el siguiente:

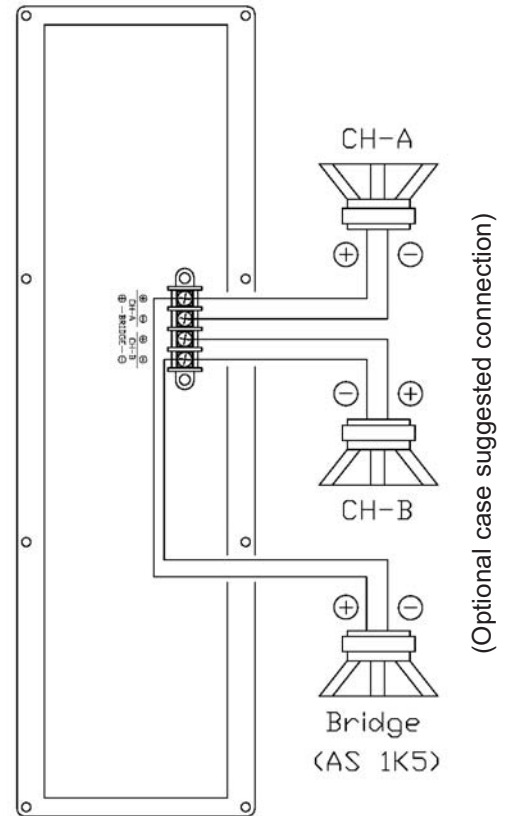

Front Panel Description

- 1 **Signal Input:** Female XLR Connector for signal input.
- 2 **Signal Link:** Male XLR Connector for signal link.
- 3 **Ethernet Connectors:** RJ45, two ports Ethernet switch.
- 4 **USB Connector:** B type USB connection.
- 5 **LED ON:** power supply ON. Blinking indicates StandBy mode.
LED SIGNAL: input signal presence indication.
LED LIMIT: lights when the DSP limiters are working.
LED CLIP: the maximum input or output has been reached.
- 6 **Quick Preset:** press the button for 3 seconds to change the desired output preset, or double click for the input preset.
ON: press SET1 button for 2s to turn on (in StandBy mode).
LEVEL: push SET 3-4 buttons simultaneously to enter LEVEL mode (both LEDs light up). Then use 3 and 4 to change level.
- 7 **Mains connection:** inlet and outlet powerCON True1 connection. It works also as a main switch, as it is a connector with breaking capacity.

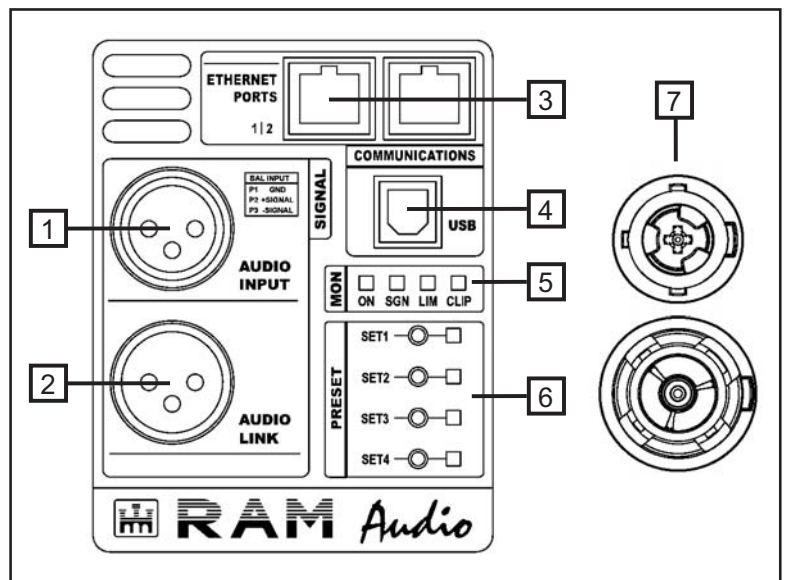

DSP Specifications

Overall:

- High performance 96kHz 120dB 32 bits AD/DA converters
- 64 bit double-precision 96kHz DSP process
- 0.6ms minimum process latency time
- Up to 2000 taps custom FIR process

Input Section:

- 2 independent inputs sections for user and advanced levels
- Gain, Mute and Phase inversion
- Input Delay: up to 40 meters
- Input EQ: 10+10 PEQ (Parametric, Shelving, LP, HP, BP, SB, AP)
- 1 or 2 inputs in SB 6K Tri model

Output Section:

- Crossover Filters: FIR and IIR (up to 48dB/oct, Butterworth / Linkwitz-Riley / Bessel)
- Output Delay: up to 40 meters (116ms) per channel
- Output IIR EQ: 12 filters per channel (Parametric, Shelving, LP, HP, BP, SB, AP)
- Output FIR EQ: 20 filters per channel (Parametric, Shelving, LP, HP, BP, SB, AP), or Custom up to 2000 taps
- RMS and Peak limiter per channel
- Optional virtual gain/delay control in user level

RAM_OCS Control

Control & Monitor:

- Standby mode for remote turn-on
- Real time impedance monitor
- Stby., Signal, Lim, Clip, Temp and Prot monitor
- Input, Output, Temperature and Current meters

Communications:

- Two ports Ethernet switch for daisy chain connection
- USB 2.0, Type B connector

Overall:

- 20 Manufacturer preset memories library
- 5 User preset memories library
- 4 Quick Preset selection
- Manufacturer/Installer/User passwords
- Independent selectable output power per channel (Z dependant)
- User control groups for virtual Eq (20 filters), Gain and Delay
- Zone management for library, stand-by and alerts information
- Smart® analysis software integration

Amplifier Specifications

Output Power Configuration (Selectable by channel)	AS 2K3		AS 1K5	
	CH-A	CH-B	CH-A	CH-B
8 ohm	1500W	400W	400W	400W
4 ohm	1500W	750W	750W	750W
2 ohm	750W	750W	750W	750W
Bridge 8 ohm	-		1500W	
Bridge 4 ohm	-		1500W	
Total Harmonic Distortion	<0.05%		<0.05%	
Efficiency	>90%		>90%	
Damping Factor (20-500Hz @8Ω)	>400		>400	
Voltage Gain	26dB-38dB		26dB-38dB	
Operational Mains voltage	85-265V AC/50-60Hz		85-265V AC/50-60Hz	
Consum. @4Ω, 1/8 r.p., 230V AC	1.7 A		1.2 A	
Power Factor	>0.95		>0.95	
Efficiency	>90%		>90%	
Dimensions				
External Plate WxH	130x443 mm		130x443 mm	
Internal Enclosure WxHxD	100x423x55 mm		100x423x55 mm	
Occupied Volume (optional case)	2 l		2 l	
Weight	1.5 kg		1.5 kg	
Connections:	XLR Input, XLR Link, powerCON True1 in-out, USB, 2x RJ45, barrier strip (in optional case)			
Protections:	Turn-on transients, Over-heating, DC, RF, Short-circuit, mismatched loads, ICL™, PMS™			



The exclamation point inside an equilateral triangle indicates the existence of internal components whose substitution may affect safety.



The lightning and arrowhead symbol warns about the presence of uninsulated dangerous voltage.



To avoid fire or electrocution risk do not expose the unit to rain or moisture. To avoid electric shock, do not open the unit. No user serviceable parts inside. In the case of disfunction, have the unit checked by qualified agents. Class I device.